

**Brief information  
on gas burners**

**–weishaupt–**

WG40N/2-A ZM-PLN 60–600 kW

WG40N/3-A ZM-PLN 60–700 kW

WG40F/2-A ZM-PLN 70–600 kW

WG40F/3-A ZM-PLN 70–700 kW

**Ultra-  
Low NO<sub>x</sub>  
in compact  
form.**



# Efficiency and low emissions.

## Key advantages

- **Low emissions**  
Meets NO<sub>x</sub> emission limits all around the world
- **High efficiency**  
Permanent magnet synchronous motor, complete with VSD (meets IE5 standards)
- **Powerful**  
60 to 600 kW / 60 to 700 kW  
Turndown 10:1 / 11:1
- **Flexible**  
Mounting and air inlet options to suit various applications
- **Safe**  
Premix operation with dual flame monitoring, integrated insulator, and twofold air filter
- **Robust and reliable**  
Construction, operation, and control are all of proven Weishaupt quality
- **Digital**  
Precise and reproducible setting, monitoring, and remote diagnosis
- **Quiet**  
Optimised laminal air and gas flow, speed controlled
- **Tried and tested**  
Premix technology successfully operating at larger capacities
- **Easy to install and maintain**  
Coded plug connections, single electrode for ignition and monitoring

**The Weishaupt WG40 PLN gas burner is suitable for use with natural gas or LPG. The burner offers sliding-two-stage or modulating load control over a range of 60–700 kW.**

The WG40 PLN is equipped with an extremely efficient permanent magnet synchronous motor and variable speed drive (VSD) as standard. Its efficiency exceeds all efficiency classes currently in place for electric motors. Burner operation is also extremely quiet.

PLN stands for Premix Low NO<sub>x</sub> – a system that combines pre-mixing with surface-stabilised combustion. That guarantees an homogeneous gas-air mixture and reliable ignition behaviour.

NO<sub>x</sub> optimisation over the entire capacity range is made possible by adjusting the O<sub>2</sub> content.

One of the main advantages of this combustion system is that, in addition to more typical boilers, heat generators with significantly smaller combustion chamber geometries can also be fired. In doing so, NO<sub>x</sub> emission values below 30 mg/kWh are achieved.

Like all Weishaupt burners, the WG40 PLN is equipped with a digital combustion manager. All essential functions, such as the supply of fuel and air, as well as flame monitoring and VSD, are measured and controlled with digital precision.

The aim is to optimise operational processes, maximise efficiency, and minimise emissions.



*The homogeneous mixture of gas and air combusts on the surface of the woven metal mesh at temperatures < 1200 °C. This combustion technology effectively inhibits the formation of thermal NO<sub>x</sub>.*

- 1** Premix chamber
- 2** Thermal insulator
- 3** Burner tube
- 4** 2-stage air filtration  
(metal gauze with pre-filter)
- 5** Air pressure switch  
(filter monitoring)
- 6** Air pressure switch  
(fan monitoring)
- 7** Flame sensor 1  
(ionisation electrode)
- 8** Flame sensor 2  
(infra-red flicker detector)
- 9** VSD as standard

## Ultra-Low NO<sub>x</sub>

NO<sub>x</sub> comparison of  
different burner versions

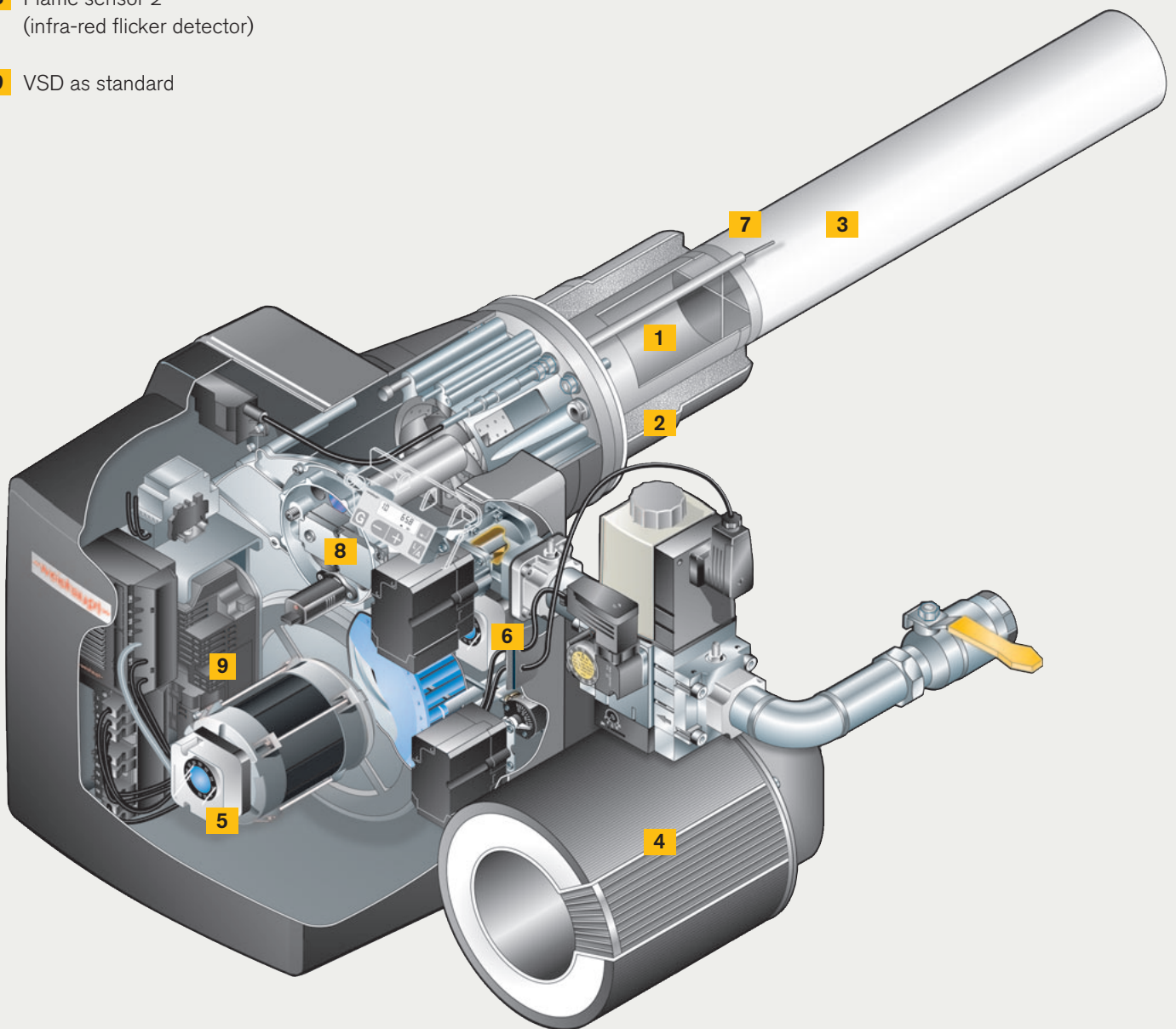
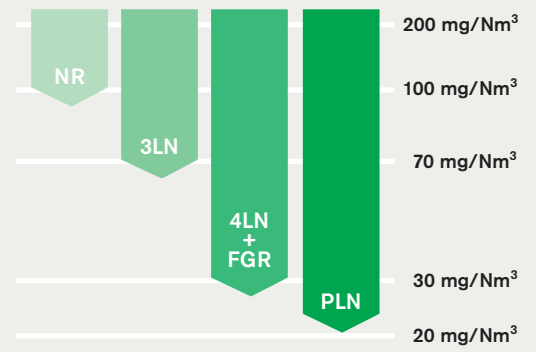

*The WG40 PLN burner is the answer to increasing calls for compact burners with minimal emissions.*

# Safe and reliable.

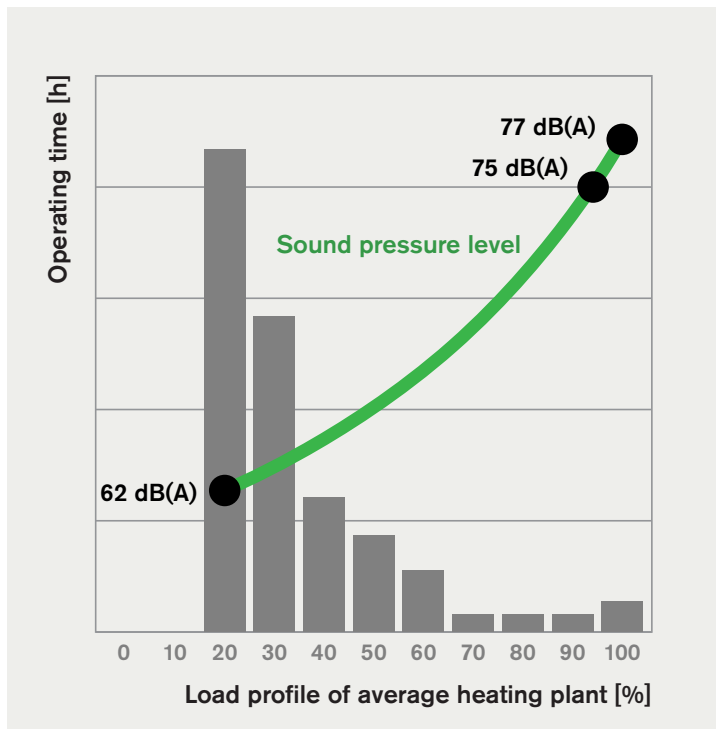

VSD does more than save electricity. It also makes the burner considerably quieter.

**A particular emphasis was placed on safety and reliability during the development of this burner range.**

Two flame monitoring methods ensure the safe operation of the burner. The ionisation electrode monitors the combustion surface, while the infra-red flicker detector secures the premix chamber and the burner tube.

The air volume, and thus indirectly the cleanliness of the air filter, is continuously monitored during burner operation by an additional air pressure switch. The necessary volume of air is thereby always guaranteed.

Thermal protection of the premix chamber, in which the ignitable

fuel-air mixture is situated, is a crucial safety aspect of this burner technology. To this end, Weishaupt has developed precisely fitting insulators that are tailored to the thermal conditions. They provide optimal protection to this sensitive area from uncontrolled heat.

The standard-design insulators for temperatures up to 850 °C are suitable for steam and hot-water boilers with through-pass or three-pass combustion chambers. Optionally, there are also high-temperature insulators that are suitable for temperatures up to 1200 °C. They provide optimal protection with other combustion chamber arrangements and for burners on thermal fluid heaters and air heaters.

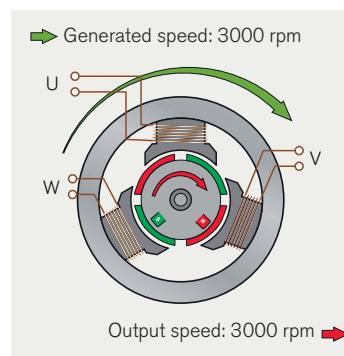

In a synchronous motor, the rotor rotates at the same rate as the stator field per the electrical frequency.

**Benefits at a glance:**

- High energy efficiency
- Extreme reliability
- Reduced surface temperature
- No rotor losses
- Compact design
- Efficiency meets IE5 standard



An optional analogue or bus expansion module makes the remote operation, diagnosis, and monitoring of the burner possible.

**Safety is the highest priority:**

- 1** Gas and air are fed separately to the mixing assembly
- 2** There is no ignitable gas-air mixture in the burner housing
- 3** The ignitable mixture in the premix chamber is protected by the thermal insulator
- 4** The homogeneous gas-air mixture is evenly distributed in the burner tube

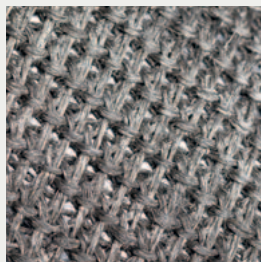
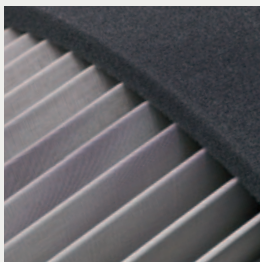
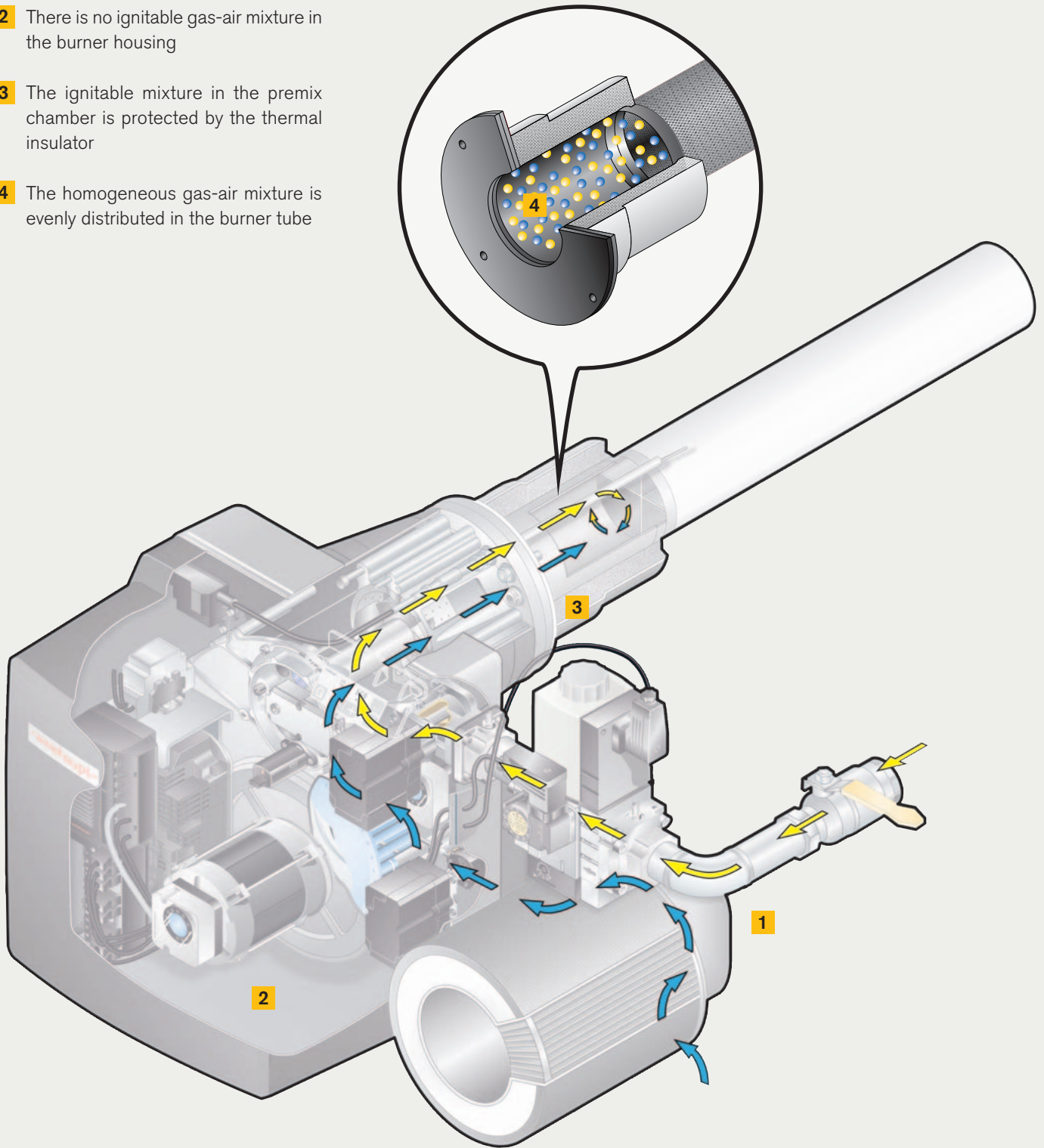

*Left: The metal gauze air filter is protected from dust by an additional prefilter sleeve.*

*Right: A microweave mat made from a high-quality alloy permits the right amount of gas-air mixture to pass.*

**Weishaupt gas burners**

**WG40../2-A ZM-PLN and WG40../3-A ZM-PLN**

**Desired NO<sub>x</sub> values and corresponding O<sub>2</sub> values to be set**

NO <sub>x</sub> [mg/Nm <sup>3</sup> ] on natural gas	O <sub>2</sub> [%] dry
20	7.5
30	6.5
50	6.0
80	5.0

Please refer to the planning documents for the combustion chamber resistance and installation altitude correction factors.

**WG40N/2-A ZM-PLN** Natural gas 60–600 kW  
**WG40F/2-A ZM-PLN** LPG 70–600 kW

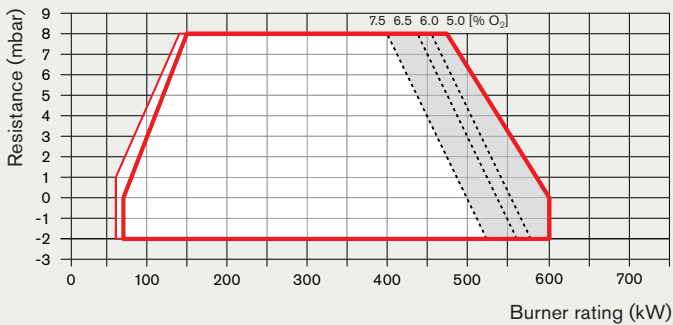

**WG40N/3-A ZM-PLN** Natural gas 60–700 kW  
**WG40F/3-A ZM-PLN** LPG 70–700 kW

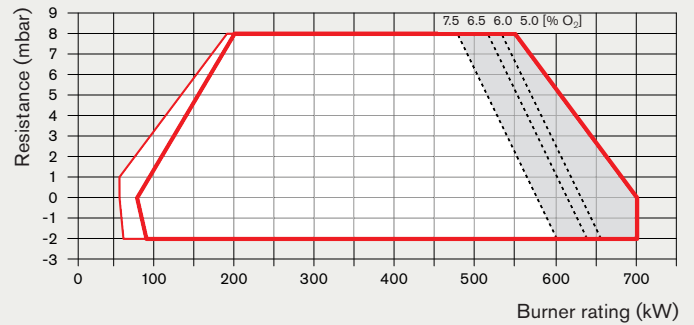

Technical data	WG40../2-A ZM-PLN	WG40../3-A ZM-PLN
Max. turndown	10:1	11:1
NO <sub>x</sub> range	20–80 mg/Nm <sup>3</sup>	
Combustion manager	W-FM25	
Protection	IP 21	
Electrical power	1.1 kW	
Efficiency class	meets IE5	
Min. gas connection pressure before ball valve	17 mbar	
Available valve train sizes	3/4" 1" 1 1/2" 2" DN65	

We reserve the right to make changes as a result of further developments.

## Dimensions

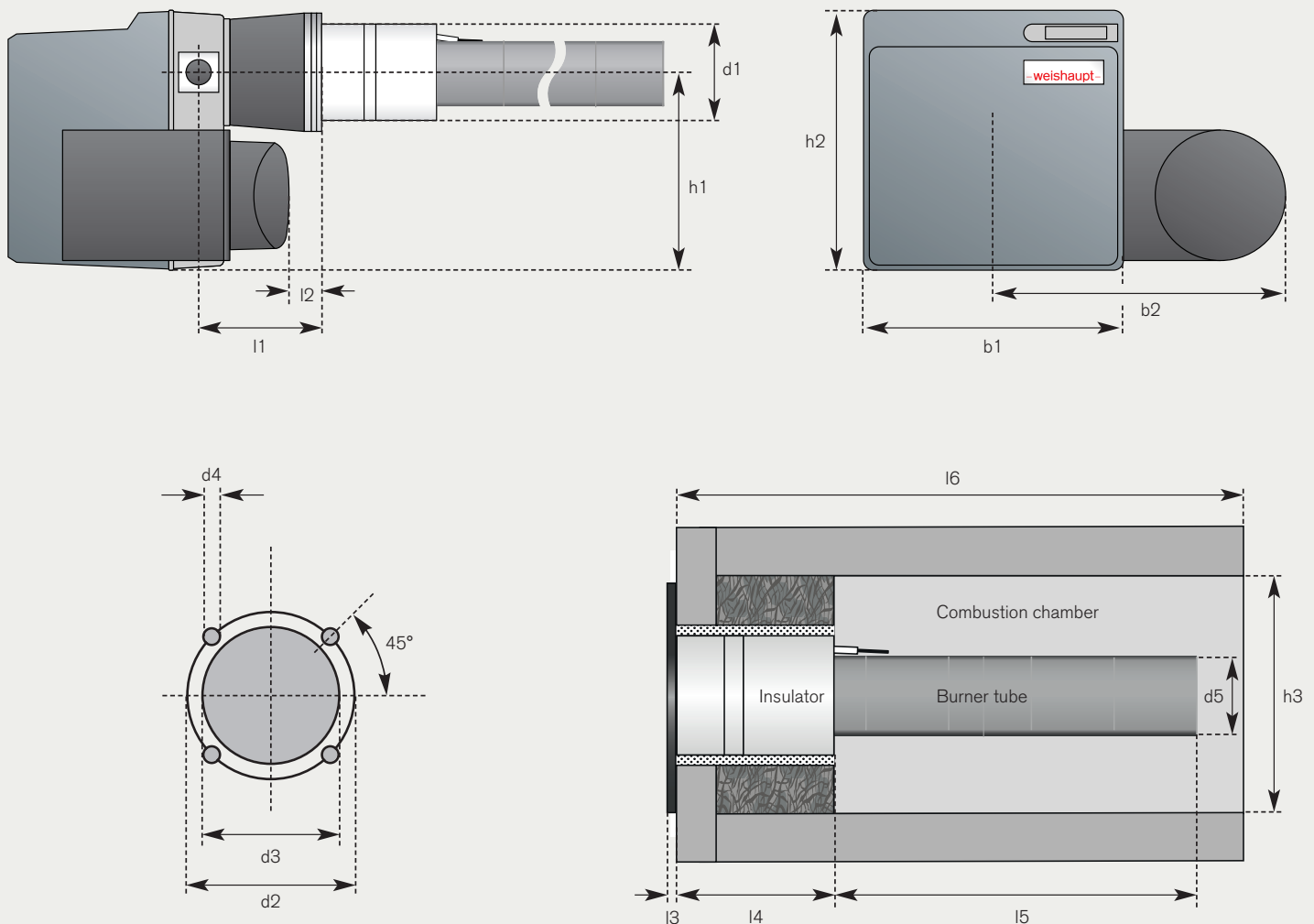

Burner / Dimension		l1	l2	l3	l4	l5	l6	b1	b2	h1	h2	h3	d1	d2	d3	d4	d5
<b>WG40.../2-A ZM-PLN</b>	mm	235	60	8	213	621	≥ 1050	450	524	360	480	320	182	200	185	M10	117
<b>WG40.../3-A ZM-PLN</b>	mm	235	60	8	213	621	≥ 1050	450	524	360	480	350	253	298	260	M12	147

We reserve the right to make changes as a result of further developments.

If you  
need  
us,  
we're  
there.

Max Weishaupt SE  
88475 Schwendi  
Tel. +49 7353 830  
info@weishaupt.de  
www.weishaupt.de

Weishaupt (UK) Ltd  
Neachells Lane, Willenhall, WV13 3RG  
Tel. (01902) 609841  
info@weishaupt.co.uk  
www.weishaupt.co.uk

Print No. 83600402, March 2021

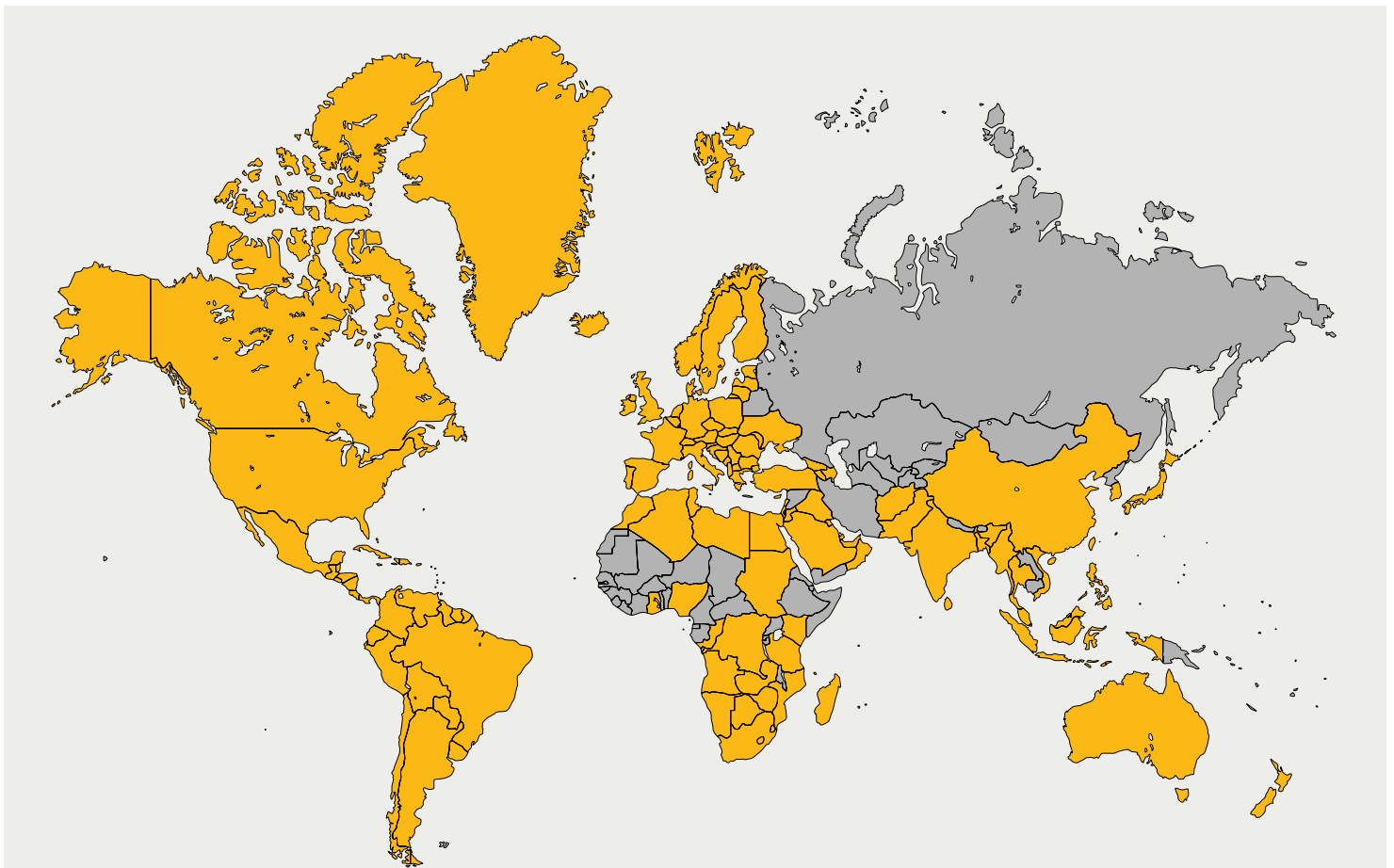

**Weishaupt worldwide:**

Afghanistan	Chile	Faroe Islands	Israel	Malaysia	Oman	South Africa	Vatican City
Algeria	China	Finland	Italy	Malta	Pakistan	Spain	Venezuela
Angola	Columbia	France	Jamaica	Mauritius	Panama	Sri Lanka	Vietnam
Argentina	Congo (D. Rep.)	French Guiana	Japan	Mexico	Paraguay	Sudan	Zambia
Australia	Congo (Rep.)	Germany	Jordan	Moldova	Peru	Suriname	Zimbabwe
Austria	Costa Rica	Ghana	Kenya	Monaco	Philippines	Sweden	
Bahrain	Croatia	Greece	Korea (S.)	Montenegro	Poland	Switzerland	
Bangladesh	Cuba	Greenland	Kosovo	Morocco	Portugal	Taiwan	
Belgium	Cyprus	Guatemala	Kuwait	Mozambique	Puerto Rico	Tanzania	
Belize	Czechia	Guyana	Latvia	Myanmar	Qatar	Thailand	
Bolivia	Denmark	Haiti	Lebanon	Namibia	Romania	Tunisia	
Bosnia-Herzegovina	Dominican Rep.	Honduras	Lesotho	Netherlands	San Marino	Turkey	
Botswana	Ecuador	Hungary	Libya	New Zealand	Saudi Arabia	UAE	
Brazil	Egypt	India	Liechtenstein	Nicaragua	Serbia	Ukraine	
Bulgaria	El Salvador	Indonesia	Lithuania	Nigeria	Singapore	United Kingdom	
Canada	Estonia	Iraq	Luxembourg	North Macedonia	Slovakia	Uruguay	
	Eswatini	Ireland	Madagascar	Norway	Slovenia	USA	